



## KTM BALL VALVES FOR INDUSTRIAL AND PROCESS APPLICATIONS

### EF190 - TWO-PIECE BALL VALVE

High performance two-piece ball valve for demanding process and utility applications



#### FEATURES

- The range includes two-piece split body ball valve designs - standard and fire tested with flanged end connections
- Full compliance with ASME B16.34 and EN 12516 - 1 with respect to the wall thickness, bolting and shaft stress analysis
- Valve pressure rating:
  - ASME Class 150/300
  - DIN PN 10/16/25/40
  - JIS 10K/20K
- Size range DN 15 to DN 300 (NPS ½ to NPS 12) - full bore
- Carbon steel or stainless steel body materials
- Purchase procedure for the carbon steel bodies specifies double material certification WCB/WCC and 1.0619/1.0625
- Investment cast body DN 15 to DN 100 (NPS ½ to NPS 4)
- Sand cast body DN 125 to DN 300 (NPS 5 to NPS 12)
- Optional casting per AD 2000 W0
- Standard ball valve with respect to the PAS1085 specification Class D
- ISO 5211 / EN 15081 top mounting plate available with male centering for easy actuation
- Double shaft seal design complies with TA Luft VDI 2440 requirements
- Patented 'SEALMASTER' shaft arrangement
- Blow-out proof shaft
- Anti-static design according to ISO 17292
- Various seat material options
- Tightness to EN 12266-1 Rate A
- Locking device standard on all valves
- Patented 'POSILOCK' handle for DN 15 to DN 50 (NPS ½ to NPS 2) full bore

#### GENERAL APPLICATION

The EF190 has been designed according to the most stringent international standards and end-user specifications to be used in criticals and hazardous applications in the chemical, petrochemical, oil & gas and related industries.

#### TECHNICAL DATA

Sizes:	DN 15 to DN 300 NPS ½ to NPS 12
Pressure rating:	PN 10/16 PN 25/40 ASME Class 150/300 JIS 10K/20K
End connection	
Flanged:	PN 10/16, PN 25/40 ASME Class 150/300 JIS 10K/20K

# KTM BALL VALVES FOR INDUSTRIAL AND PROCESS APPLICATIONS

## EF190 - TWO-PIECE BALL VALVE

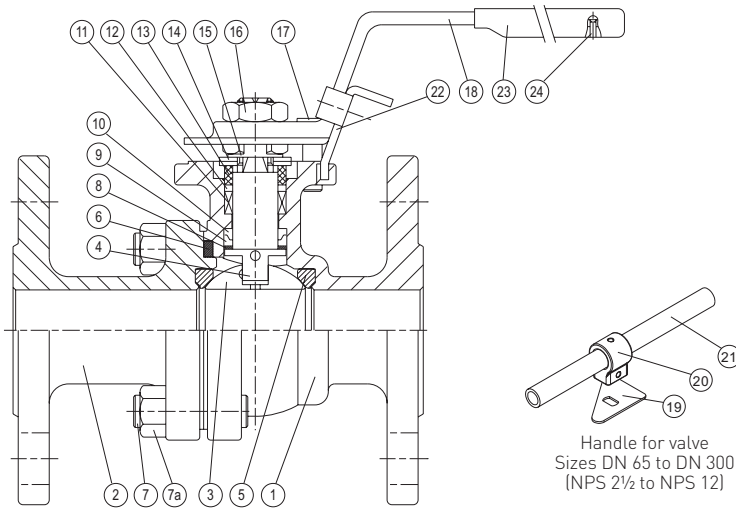

Handle for valve  
 Sizes DN 65 to DN 300  
 (NPS 2½ to NPS 12)

### MATERIALS OF CONSTRUCTION

No.	Parts name	Material	Quantity
1*	Body	EN 1.4408/1.0619	1
2*	Cap	EN 1.4408/1.0619	1
3	Ball	EN 1.4408	1
4	Anti-static shaft	A276 Type 316 (Note 1)	1
5	Ball seat	PTFE	2
6	Body seal	PTFE	1
7	Stud	A193 Gr. B8 / A193 Gr. B7	4-26
7a	Nut	A194 Gr. 8 / A194 Gr. 2H	4-26
8	Lower shaft seal	50% SS powder / 50% PTFE	1
9	Compress ring	316L SS DN 15 to DN 100 (NPS ½ to NPS 4) / 316 SS DN 125 to DN 300 (NPS 5 to NPS 12)	1
10	Upper shaft seal	TFM 1600	1
11	V-ring shaft packing	PTFE	1 set
12	Thrust washer	50% SS powder / 50% PTFE	1
13	Gland	304 SS	1
14	Belleville washer	301 SS	2
15	Lock saddle	Stainless steel	1
16	Shaft nut	304 SS	1-2
17	Stop bolt	Stainless steel	1-2
18	Handle (DN 15-50)	CF8	1
19	Triangle stopper (DN 65-300)	Stainless steel	1
20	Handle adapter (DN 65-300)	CF8 DN 65 to DN 125 (NPS 2½ to NPS 5) / A536 DN 150 to DN 300 (NPS 6 to NPS 12)	1
21	Handle (DN 65-300)	SGP Zn plating	1
22	Locking trigger	Stainless steel	1
23	Handle sleeve	Vinyl	1
24	Rivet	304 SS	1

### MAXIMUM ALLOWABLE SHAFT TORQUE (Nm)

Size DN	Body material	Class 150		Class 300	
		PN 10/16, 10K	PN 25/40, 20K	PN 10/16, 10K	PN 25/40, 20K
15/20	SS/CS	25	25		
25/32	SS/CS	40	40		
40/50	SS/CS	78	78		
65/80	SS/CS	318	318		
	SS	392	392		
100/125	SS	637	1382		
	CS	637	2252		
150	SS	1382	1382		
	CS	2252	2252		
200	SS	2850	2850		
	CS	4644	4644		
250	SS	2850	2850		
	CS	4644	4644		
300	SS	2850	2850		
	CS	4644	4644		

SS = Stainless Steel, CS = Carbon Steel

Note 1: Standard shaft material

\* For Class valves, the body & cap material will be ASTM A351 Gr. CF8M / ASTM A216 Gr. WCB

\* For JIS designated valves, the body & cap material will be SCS14A/SCPH2

### STANDARD SHAFT MATERIAL

Body material	Size	Class 150, 10K, PN 10/16	Class 300, 20K, PN 25/40
CF8M,	DN 15 - DN 125 (NPS ½ - NPS 5)	316	316
SCS14A,	DN 150 (NPS 6)	316	2205 (A276-S31803)
1.4408	DN 200 - DN 300 (NPS 8 - NPS 12)	2205 (A276-S31803)	2205 (A276-S31803)
WCB,	DN 15 - DN 125 (NPS ½ - NPS 5)	316	316
SCPH2,	DN 150 (NPS 6)	316	17-4 (A564-630)
1.0619	DN 200 - DN 300 (NPS 8 - NPS 12)	17-4 (A564-630)	17-4 (A564-630)

# KTM BALL VALVES FOR INDUSTRIAL AND PROCESS APPLICATIONS

## EF190F - SPLIT BODY FLANGED BALL VALVE - FIRE TESTED

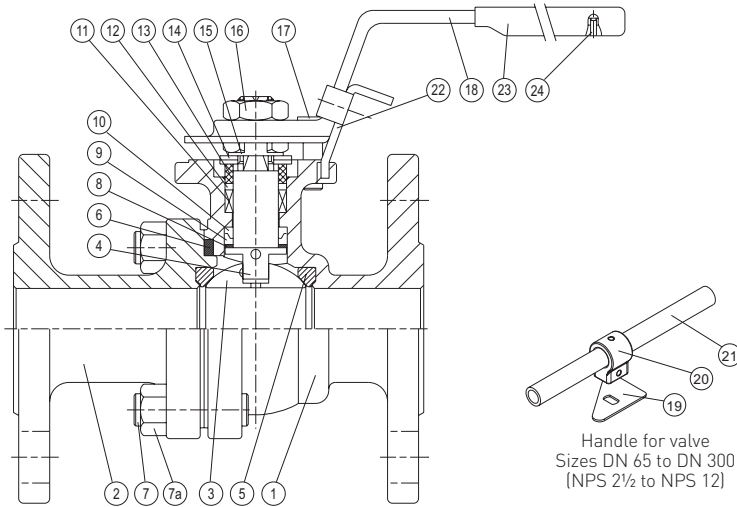

### MATERIALS OF CONSTRUCTION

No.	Parts name	Material	Quantity
1*	Body	EN 1.4408/1.0619	1
2*	Cap	EN 1.4408/1.0619	1
3	Ball	EN 1.4408	1
4	Anti-static shaft	A276 type 316 (Note 1)	1
5	Ball seat	PTFE	2
6	Body seal	Graphite DN 15 to DN 100 (NPS ½ to NPS 4) / 316 SS spiral wound graphite DN 125 to DN 300 (NPS 5 to NPS 12)	1
7	Stud	A193 Gr. B8 / A193 Gr. B7	4-26
7a	Nut	A194 Gr. 8 / A194 Gr. 2H	4-26
8	Lower shaft seal	50% SS powder / 50% PTFE	1
9	Compress ring	316L SS DN 15 to DN 100 (NPS ½ to NPS 4) / 316 SS DN 125 to DN 300 (NPS 5 to NPS 12)	1
10	Upper shaft seal	Graphite	1
11	Shaft packing	Graphite	1 set
12	Thrust washer	50% SS powder / 50% PTFE	1
13	Gland	304 SS	1
14	Belleville washer	301 SS	2
15	Lock saddle	Stainless steel	1
16	Shaft nut	304 SS	1-2
17	Stop bolt	Stainless steel	1-2
18	Handle DN 15 to DN 50 (NPS ½ to NPS 2)	CF8	1
19	Triangle stopper DN 65 to DN 300 (NPS 2½ to NPS 12)	Stainless steel	1
20	Handle adapter DN 65 to DN 300 (NPS 2½ to NPS 12)	CF8 DN 65 to DN 125 (NPS 2½ to NPS 5) / A536 DN 150 to DN 300 (NPS 6 to NPS 12)	1
21	Handle DN 65 to DN 300 (NPS 2½ to NPS 12)	SGP Zn plating	1
22	Locking trigger	Stainless steel	1
23	Handle sleeve	Vinyl	1
24	Rivet	304 SS	1

Note 1: Standard shaft material

\* For Class valves, the body & cap material will be ASTM A351 Gr. CF8M / ASTM A216 Gr. WCB

\* For JIS designated valves, the body & cap material will be SCS14A/SCPH2

### STANDARD SHAFT MATERIAL

Body material	Size	Class 150, 10K, PN 10/16	Class 300, 20K, PN 25/40
CF8M,	DN 15 - DN 125 (NPS ½ - NPS 5)	316	316
SCS14A,	DN 150 (NPS 6)	316	2205 (A276-S31803)
1.4408	DN 200 - DN 300 (NPS 8 - NPS 12)	2205 (A276-S31803)	2205 (A276-S31803)
WCB,	DN 15 - DN 125 (NPS ½ - NPS 5)	316	316
SCPH2,	DN 150 (NPS 6)	316	17-4 (A564-630)
1.0619	DN 200 - DN 300 (NPS 8 - NPS 12)	17-4 (A564-630)	17-4 (A564-630)

### MAXIMUM ALLOWABLE SHAFT TORQUE (Nm)

Size DN	Body material	Class 150		Class 300	
		PN 10/16, 10K	PN 25/40, 20K	PN 10/16, 10K	PN 25/40, 20K
15/20	SS/CS	25	25		
25/32	SS/CS	40	40		
40/50	SS/CS	78	78		
65/80	SS/CS	318	318		
100/125	SS/CS	392	392		
150	SS	637	1382		
	CS	637	2252		
200	SS	1382	1382		
	CS	2252	2252		
250	SS	2850	2850		
	CS	4644	4644		
300	SS	2850	2850		
	CS	4644	4644		

SS = Stainless Steel, CS = Carbon Steel

### FEATURES

- Secondary metal to metal seating surface
- Flexible graphite body and shaft packing for high temperature resistance
- Fire tested to API 607 5th ed. / ISO 10497 up to DN 300 (NPS 12)

# KTM BALL VALVES FOR INDUSTRIAL AND PROCESS APPLICATIONS

## EF190/EF190F - SPLIT BODY FLANGED BALL VALVE

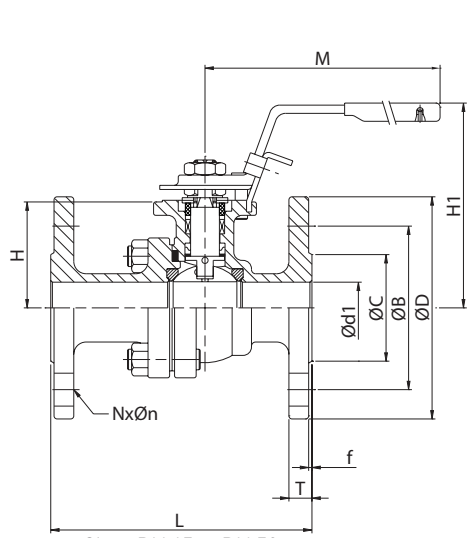

Sizes DN 15 to DN 50  
(NPS 1/2 to NPS 2)

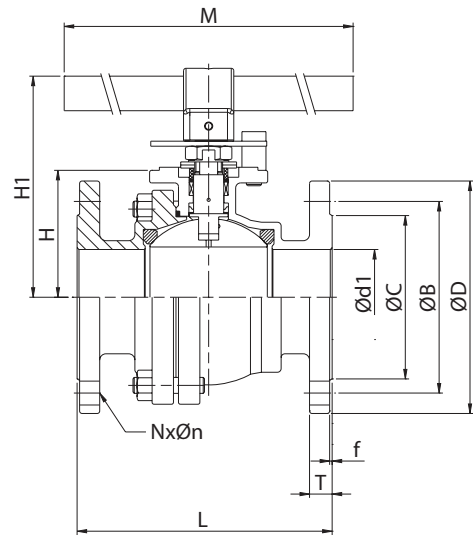

Sizes DN 65 to DN 300  
(NPS 2 1/2 to NPS 12)

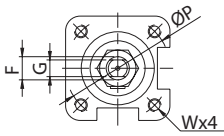

DN 15 DN 100  
(NPS 1/2 to NPS 4)

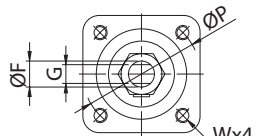

DN 125 to DN 200  
(NPS 5 to NPS 8)

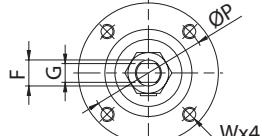

DN 250 to DN 300  
(NPS 10 to NPS 12)

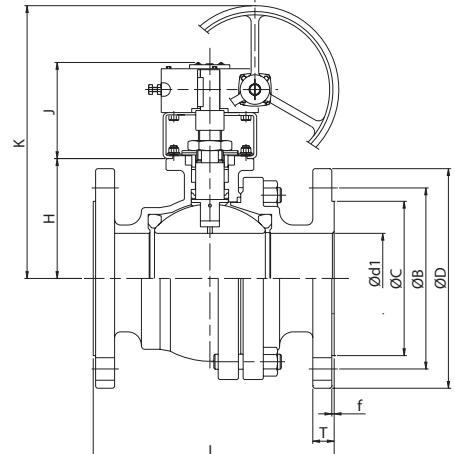
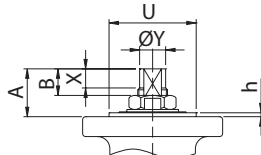
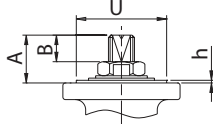
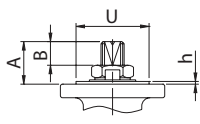

DN 250 to DN 300  
(NPS 10 to NPS 12)  
Optional

### DIMENSIONS (mm)

DN	NPS	A	ØP	F	G	B	U	h	W	M	H	H1	J	K	X	Y
15	1/2	20.3	42	9.7	6.3	12.0	30	2	M5	135	38.5	82	N/A	N/A	-	-
20	3/4	20.5	42	9.7	6.3	12.4	30	2	M5	135	42.0	86	N/A	N/A	-	-
25	1	21.6	50	11.2	8.0	14.0	35	3	M6	165	51.5	98	N/A	N/A	-	-
32	1 1/4	21.6	50	11.2	8.0	14.0	35	3	M6	165	56.2	102	N/A	N/A	-	-
40	1 1/2	26.0	70	16.0	9.5	16.2	55	3	M8	200	65.5	119	N/A	N/A	-	-
50	2	26.0	70	16.0	9.5	16.2	55	3	M8	200	74.5	128	N/A	N/A	-	-
65	2 1/2	43.0	102	22.3	17.0	24.7	70	3	M10	*495	88.0	162	N/A	N/A	-	-
80	3	43.5	102	22.3	17.0	25.2	70	3	M10	*495	101.0	172	N/A	N/A	-	-
100	4	49.0	102	28.6	17.0	30.0	70	3	M10	*595	122.0	197	N/A	N/A	-	-
125	5	53.6	102	28.6	17.0	33.0	70	3	M10	*595	140.0	226	161	393	-	-
150	6	65.0	125	34.0	23.0	39.0	85	3	M12	800	167.0	281	190	513	-	-
200	8	65.0	125	34.0	23.0	39.0	85	3	M12	1100	203.0	317	190	549	-	-
250	10	83.5	140	50.0	30.0	52.0	100	4	M16	1100	263.0	378	221	625	40	47
300	12	83.5	140	50.0	30.0	52.0	100	4	M16	1100	305.0	420	221	667	40	47

N/A = Not available

\* For NPS 2 1/2 to NPS 5 JIS 10K/20K, W = M12

# KTM BALL VALVES FOR INDUSTRIAL AND PROCESS APPLICATIONS

## EF190/EF190F - SPLIT BODY FLANGED BALL VALVE

### ASME 150/300 DIMENSIONS (mm)

DN	NPS	Ø B		Ø D		L		N		T		Ø n		Ø C	Ø d1	f	Wt (kg)	
		150	300	150	300	150	300	150	300	150	300	150	300				150	300
15	½	60.5	66.5	89.0	95.0	108.0	140.0	4	4	11.2	14.3	16.0	16.0	35	15	1.6	1.82	2.20
20	¾	70.0	82.5	98.6	117.0	117.0	152.0	4	4	11.2	15.9	16.0	19.0	43	20	1.6	2.12	3.25
25	1	79.5	89.0	108.0	124.0	127.0	165.0	4	4	11.2	17.5	16.0	19.0	51	25	1.6	3.04	4.48
40	1½	98.5	114.5	127.0	156.0	165.0	190.0	4	4	14.2	20.7	16.0	22.0	73	40	1.6	5.80	8.70
50	2	120.5	127.0	152.5	165.0	178.0	216.0	4	8	15.9	22.3	19.0	19.0	92	50	1.6	8.36	11.20
60	2½	139.5	149.0	178.0	190.0	190.0	241.0	4	8	17.5	25.4	19.0	22.0	105	65	1.6	15.00	19.00
80	3	152.5	168.0	190.5	210.0	203.0	283.0	4	8	19.1	28.6	19.0	22.0	127	76	1.6	19.92	28.00
100	4	190.5	200.0	229.0	254.0	229.0	305.0	8	8	23.9	31.8	19.0	22.0	157	100	1.6	32.90	43.72
125	5	215.9	234.9	254.0	279.4	355.6	381.0	8	8	23.8	34.9	22.2	22.2	186	125	1.6	49.00	71.00
150	6	241.3	269.9	279.4	317.5	393.7	403.4	8	12	25.4	36.6	22.2	22.2	216	150	1.6	75.00	100.00
200	8	298.4	330.2	342.9	381.0	457.2	501.7	8	12	28.6	41.3	22.2	25.4	270	201	1.6	128.00	172.00
250	10	361.9	387.3	406.4	444.5	533.4	568.5	12	16	30.2	47.6	25.4	28.6	324	250	1.6	215.00	291.00
300	12	431.8	450.8	482.6	520.7	609.6	647.7	12	16	31.8	50.8	25.4	31.8	381	300	1.6	254.00	423.00

### DIN PN 10/16/25/40 DIMENSIONS (mm)

DN	NPS	PN	Ø B	Ø C	Ø D	L	L*	N	T	Ø n	Ø d1	f	Wt (kg)	
													F1	F4/F5
15	½	10/16/25/40	65	45	95	115	130	4	16	14	15	2	2.42	2.46
20	¾	10/16/25/40	75	58	105	120	150	4	18	14	20	2	3.24	3.08
25	1	10/16/25/40	85	68	115	125	160	4	18	14	25	2	4.42	4.18
32	1¼	10/16/25/40	100	78	140	130	180	4	18	18	32	2	6.10	5.62
40	1½	10/16/25/40	110	88	150	140	200	4	18	18	40	2	7.94	7.40
50	2	10/16/25/40	125	102	165	150	230	4	20	18	50	2	10.50	9.76
65	2½**	10/16	145	122	185	170	290	4	18	18	65	2	17.00	16.60
		25/40	145	122	185	170	290	8	22	18	65	2	18.30	16.22
80	3	10/16	160	138	200	180	310	8	20	18	80	2	21.50	21.40
		25/40	160	138	200	180	310	8	24	18	80	2	24.90	21.34
100	4	10/16	180	158	220	190	350	8	20	18	100	2	34.00	27.72
		25/40	190	162	235	190	350	8	24	22	100	2	37.20	31.42
125	5	10/16	210	188	250	325	400	8	22	18	125	2	50.00	48.00
		25/40	220	188	270	325	400	8	26	26	125	2	60.00	57.00
150	6	10/16	240	212	285	350	480	8	22	22	150	2	78.00	73.00
		25/40	250	218	300	350	480	8	28	26	150	2	92.00	82.00
200	8	10	295	268	340	400	600	8	24	22	200	2	124.00	98.00
		16	295	268	340	400	600	12	24	22	200	2	124.00	98.00
		25	310	278	360	400	600	12	30	26	200	2	164.00	148.00
		40	320	285	375	400	600	12	34	30	200	2	164.00	148.00
250	10	10	350	320	395	450	730	12	26	22	250	2	270.00	203.00
		16	355	320	405	450	730	12	26	26	250	2	270.20	203.00
300	12	10	400	370	445	500	850	12	26	22	300	2	N/A	233.00
		16	410	378	460	500	850	12	28	26	300	2	N/A	233.00

L dimensions DN 15 to DN 100 – ISO 5752 series 14 (F4); DN 125 to DN 300 – ISO 5752 series 15 (F5) or DN 15 to DN 300 – EN 558 series 27

\* L dimensions DN15 to DN 300 – ISO 5752 series 1 or EN 558 series 1

\*\* For DN 65, PN 25/40 F1, please contact your sales representative

### JIS 10K/20K DIMENSIONS (mm)

NPS		Ø B		Ø C		Ø D		L		N		T		Ø n		J	K	Ø d1	f	H	Wt (kg)	
		10K	20K	10K	20K	10K	20K	10K	20K	10K	20K	10K	20K	10K	20K							
15A	½	70	70	51	51	95	95	108	140	4	4	12	14	15	15	N/A	N/A	15	1	38.5	2.10	2.36
20A	¾	75	75	56	56	100	100	117	152	4	4	14	16	15	15	N/A	N/A	20	1	42.0	2.50	2.80
25A	1	90	90	67	67	125	125	127	165	4	4	14	16	19	19	N/A	N/A	25	1	51.5	3.86	4.55
32A	1¼	100	N/A	76	N/A	135	N/A	140	N/A	4	N/A	16	N/A	19	N/A	N/A	N/A	32	2	56.2	5.50	N/A
40A	1½	105	105	81	81	140	140	165	190	4	4	16	18	19	19	N/A	N/A	40	2	65.5	6.48	7.16
50A	2	120	120	96	96	155	155	178	216	4	8	16	18	19	19	N/A	N/A	50	2	74.5	8.40	8.92
65A	2½	140	140	116	116	175	175	190	241	4	8	18	20	19	22	N/A	N/A	65	2	90.0	13.80	15.50
80A	3	150	160	126	136	185	200	203	283	8	8	18	22	19	23	N/A	N/A	76	2	101.0	18.60	23.24
100A	4	175	185	151	160	210	225	229	305	8	8	18	24	19	23	N/A	N/A	100	2	122.0	27.36	34.10
125A	5	210	225	185	195	250	270	356	381	8	8	20	26	23	25	161	393	125	2	140.0	46.00	69.00
150A	6	240	260	212	230	280	305	394	403	8	12	22	28	23	25	190	513	150	2	167.0	73.00	92.00
200A	8	290	305	262	275	330	350	457	502	12	12	22	30	23	25	190	549	201	2	203.0	120.00	139.00
250A	10	355	380	324	345	400	430	533	568	12	12	24	34	25	27	221	625	250	2	263.0	201.00	291.00
300A	12	400	430	368	395	445	480	610	648	16	16	24	36	25	27	221	667	300	3	305.0	254.00	423.00

N/A = Not available

# KTM BALL VALVES FOR INDUSTRIAL AND PROCESS APPLICATIONS

EF190

POSILOCK® handle

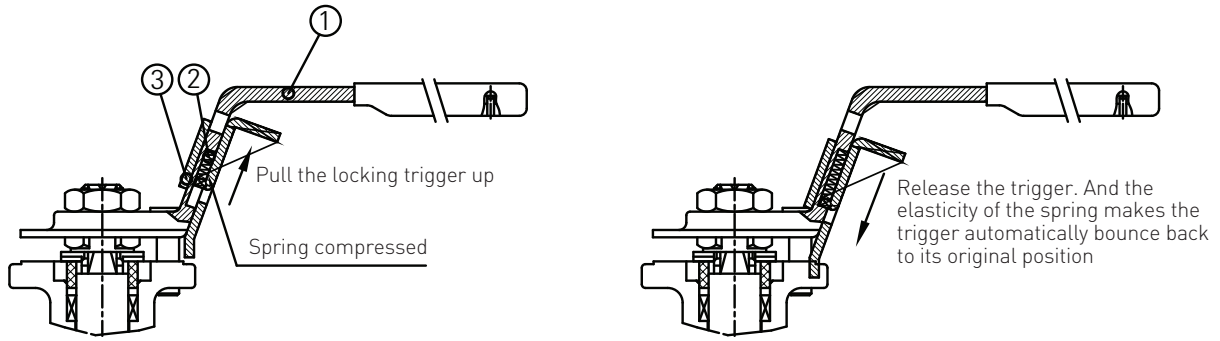

## FEATURES

- Simple construction
- Smooth action for locking trigger
- Wrapped locking trigger design prevents the spring from coming out
- The elasticity of the spring makes the trigger automatically bounce back to its original position, which keeps the plate in position for firm locking. This also avoids unwanted valve operation caused by accident.

## PARTS LIST

No.	Parts name
1	Handle
2	Spring
3	Locking trigger

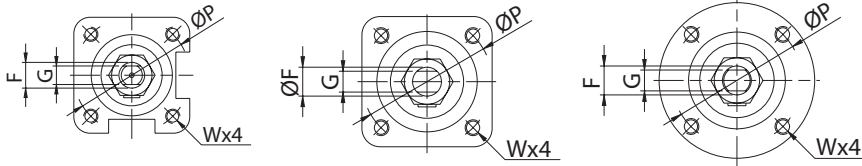

## TOP WORK DIMENSIONS (mm) - SPIGOT

Flange type	Ø P	W
F03	36	M5
F04	42	M5
F05	50	M6
F07	70	M8
F10	102	M10
F12	125	M12
F14	140	M16

## EF190/EF190F BREAK-AWAY TORQUE (Nm) - PTFE SEAT

Size DN	Size NPS	Differential pressure: bar (psi)					
		0	6.9 (100)	13.8 (200)	20.7 (300)	27.6 (400)	34.5 (500)
15	1/2	8.4	8.6	8.7	8.9	9.1	9.5
20	3/4	11.5	12.5	12.5	13.0	13.0	13.5
25	1	13.5	13.5	14.0	14.5	15.0	16.0
32	1 1/4	14.0	14.2	14.4	15.3	16.8	18.1
40	1 1/2	23.5	24.0	24.5	25.0	25.5	26.0
50	2	30.5	31.0	31.5	31.5	32.0	32.5
65	2 1/2	42.5	46.0	50.0	52.0	58.0	65.0
80	3	58.0	82.0	100.0	125.0	145.0	155.0
100	4	82.0	88.0	110.0	145.0	175.0	210.0
125	5	125.0	130.0	150.0	190.0	240.0	300.0
150	6	175.0	240.0	305.0	490.0	650.0	750.0
200	8	180.0	300.0	420.0	690.0	870.0	-
250	10	350.0	760.0	1250.0	1700.0	2050.0	-
300	12	470.0	870.0	1500.0	2350.0	-	-

## NOTES

1. Increase by 25% for MG1241, carbon & SS filled seat.
2. Increase by 15% for dry gas or oil free products.
3. Increase by 40% for dry gas (-10°C and below).
4. Increase by 40% for gas below -10°C or for liquid with slurry powder.
5. Increase by 40% for high viscosity fluid.
6. For actuator sizing, we recommend to add at least 20% of the break-away torque of valve as safety factor.

# KTM BALL VALVES FOR INDUSTRIAL AND PROCESS APPLICATIONS

## SEALMASTER®

### PATENTED SEALMASTER® SHAFT SEAL ARRANGEMENT

Our extremely high cycle shaft sealing design is accomplished by double sealing system. The high performance of KTM EF190 Ball Valves is mainly due to unique SEALMASTER® shaft seal arrangement, which provides a primary sealing. It has been specially designed and constructed to prevent line fluid permeation and resultant leakage. On top of this arrangement are multiple layers of V-Ring shaft packing this acts as secondary sealing. A set of Belleville washers automatically and constantly compresses the seals to adjust for wear, pressure and temperature fluctuations. Every KTM EF190 Ball Valve is a stalwart barrier against Fugitive Emissions.

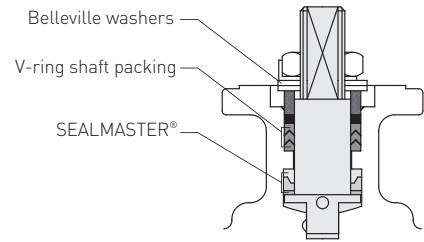

### EXPLANATION OF SEALMASTER®

The live loaded SEALMASTER® is a combination of 3 components; (A) a cup and cone PFA/TFE upper thrust seal, (B) a cup and cone sintered 316SS center load ring and (C) a flat SS/TFE lower thrust seal. When tightened, the live loaded shaft pulls up and compressing the shaft thrust seals. As this happens, material from upper and lower thrust seal extrude between shaft and body enclosures. (See 1-6). The surfaces between the bottom of lower thrust seal and top of shaft flange are smooth and all rotation occurs between these two surfaces leaving the shaft thrust seal 'static' to create the best possible seal. As rotation continues, components bed in and keep seal performance constant with usage.

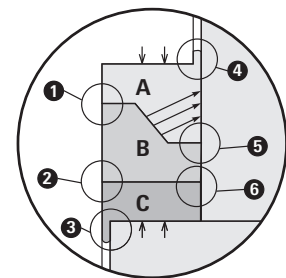

### MAIN FEATURES OF SEALMASTER® - PATENTED SHAFT SEAL ARRANGEMENT

- MULTIPLE sealing up to 6 areas (see view 1 - 6).
- Encapsulated STATIC sealing achieved on upper thrust seal.
- Constant sealing force transmitted to shaft (see arrow) making shaft primary sealing 'positive'.
- Excellent wear resistance on lower thrust seal (50% SS filled PTFE).
- Reduced seal friction as a result of better than Ra 0.8 m (150 grit) shaft finish.

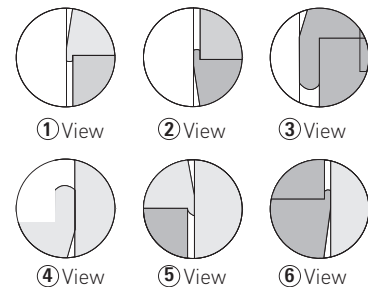

### SHAFT SEAL ARRANGEMENT

Patented 'SEALMASTER®'  
 DN 15 to DN 300 (NPS ½ to NPS 12) EF190/EF190F

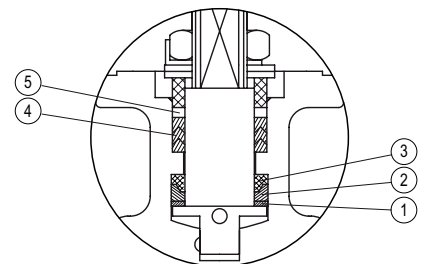

No.	Part name	Material
1	Lower thrust washer	50% SS powder / 50% PTFE
2	Compress ring	316 SS
3	Upper thrust washer	TFM 1600
4	V-ring shaft packing	PTFE *
5	Thrust washer	50% SS powder / 50% PTFE

\* For the EF190F, the V-ring PTFE shaft packing is replaced by graphite packing

# KTM BALL VALVES FOR INDUSTRIAL AND PROCESS APPLICATIONS

## EF190/EF190F - PRESSURE/TEMPERATURE CHARTS

**EF190/EF190F - ASME**  
**Split-body flanged ball valve**  
**DN 15 to DN 20 (NPS ½ to NPS ¾) - full bore**

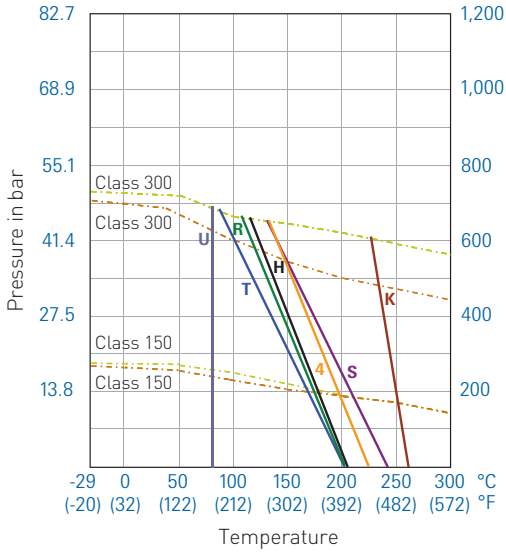

**EF190/EF190F - ASME**  
**Split-body flanged ball valve**  
**DN 25 to DN 65 (NPS 1 to NPS 2½) - full bore**

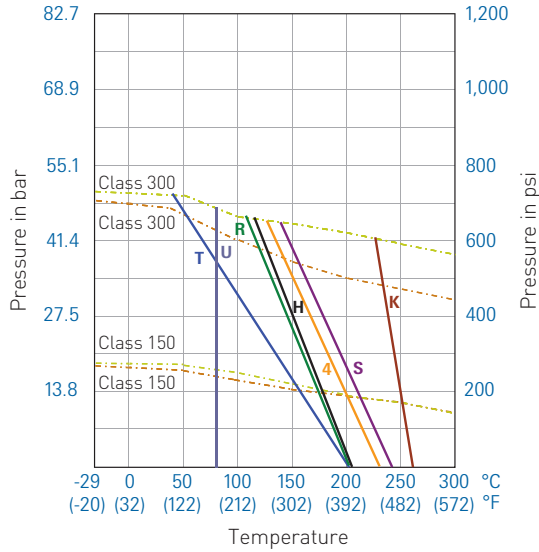

**EF190/EF190F - ASME**  
**Split-body flanged ball valve**  
**DN 80 to DN 100 (NPS 3 to NPS 4) - full bore**

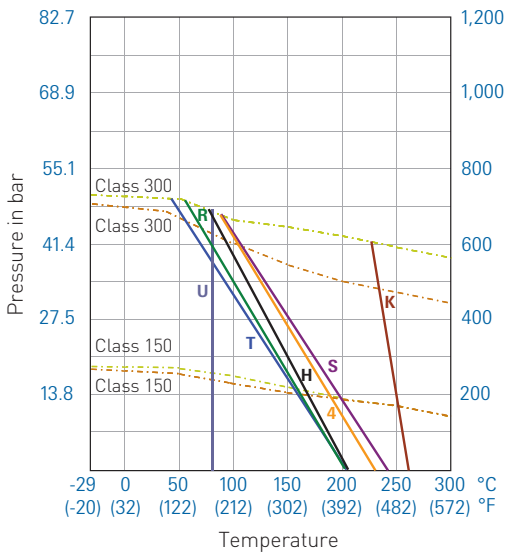

**EF190/EF190F - ASME**  
**Split-body flanged ball valve**  
**DN 125 to DN 300 (NPS 5 to NPS 12) - full bore**

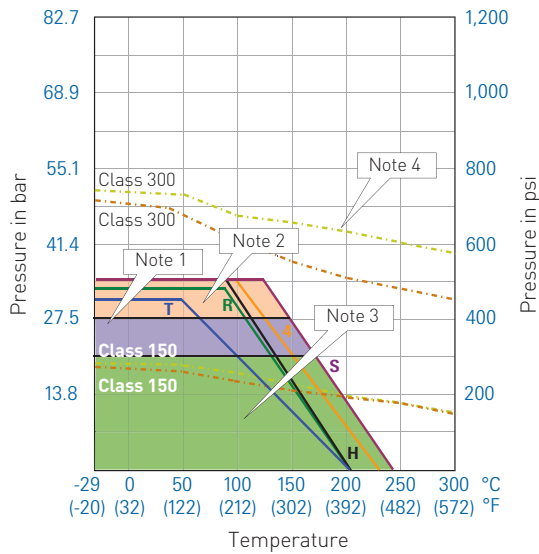

- = 1.0619 body rating
- = 1.4408 body rating
- = WCB body rating
- = CF8M body rating
- T** = PTFE
- R** = RPTFE
- 4** = 25% carbon filled PTFE
- S** = 50% SS filled PTFE
- U** = UHMWP
- K** = PEEK (450G)
- H** = TFM 1600

**NOTES**

1. NPS 8 & 10 maximum operating pressure 27.6 bar (400 psig). Please consult factory for this range of application.
2. NPS 5 & 6 maximum operating pressure 34.5 bar (500 psig).
3. NPS 12 maximum operating pressure 20.7 bar (300 psig).
4. 50% SS filled PTFE and 25% carbon filled PTFE shall not exceed this rating line for ASME Class 300.



# KTM BALL VALVES FOR INDUSTRIAL AND PROCESS APPLICATIONS

## EF190/EF190F - PRESSURE/TEMPERATURE CHARTS

**EF190/EF190F - DIN**  
**Split-body flanged ball valve**  
**DN 15 to DN 20 (NPS ½ to NPS ¾) - full bore**

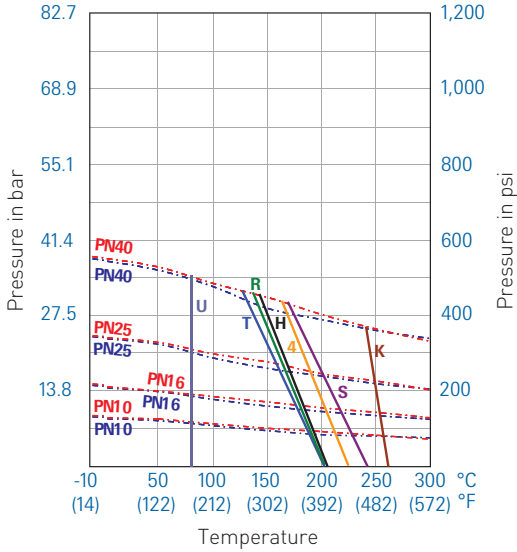

**EF190/EF190F - DIN**  
**Split-body flanged ball valve**  
**DN 25 to DN 65 (NPS 1 to NPS 2½) - full bore**

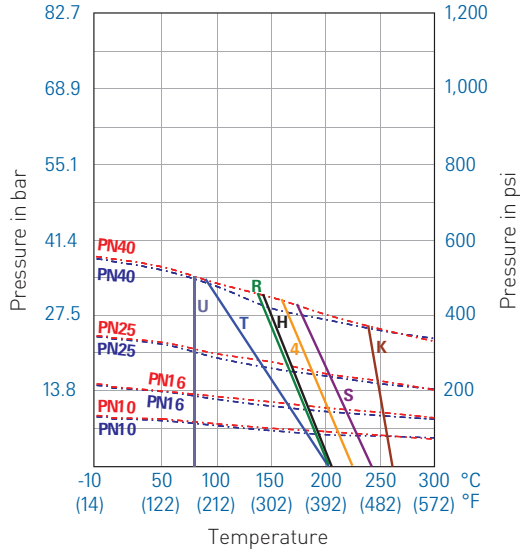

**EF190/EF190F - DIN**  
**Split-body flanged ball valve**  
**DN 80 to DN 100 (NPS 3 to NPS 4) - full bore**

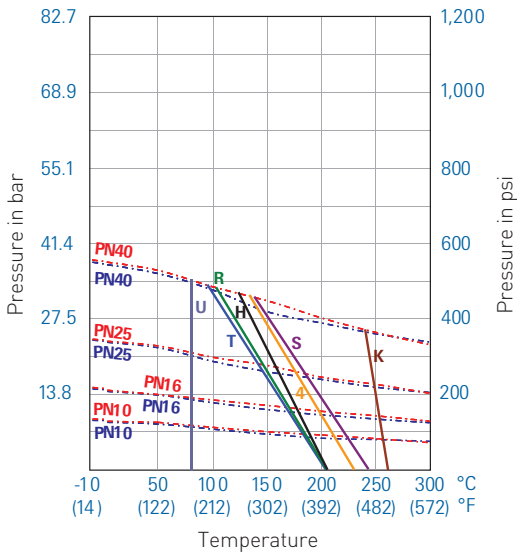

**EF190/EF190F - DIN**  
**Split-body flanged ball valve**  
**DN 125 to DN 300 (NPS 5 to NPS 12) - full bore**

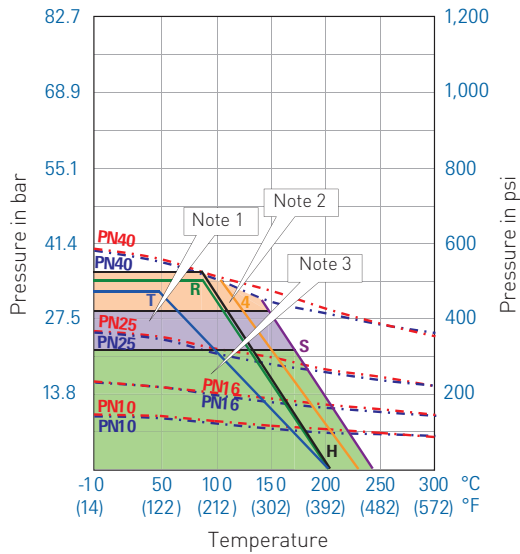

- = 1.0619 body rating
- .- = 1.4408 body rating
- = WCB body rating
- = CF8M body rating
- T = PTFE
- R = RPTFE
- 4 = 25% carbon filled PTFE
- S = 50% SS filled PTFE
- U = UHMWP
- K = PEEK (450G)
- H = TFM 1600

**NOTES**

1. DN 200 & 250 maximum operating pressure 27.6 bar (400 psig). Please consult factory for this range of application.
2. DN 125 & 150 maximum operating pressure 34.5 bar (500 psig).
3. DN 300 maximum operating pressure 20.7 bar (300 psig).