



Three Piece Sanitary Ball Valve, Tube Bore, Clamp end, ISO 5211 Direct Mounting type, PN 63/40

Fig no. V-Z58TC

Tube Bore

1/2" - 4" DN15 ~ DN100



Features:

- Investment casting body
- Blow-out-proof stem
- In-line Maintenance, ISO 5211 Direct mounting
- For Hygenic application

Standard Compliance :

- Body wall thickness : ASTM B16.34
- Clamp end : 3A
- Face to face : MD's standard
- Body material : ASTM A351
- Pressure testing : EN 12266/ API 598

Specification :

- End Connection : Clamp end
- Working pressure : 1000 psi (PN 63) for DN8- DN 50
800 psi (PN40) for DN 65-DN100
- Temperature : -20 ~ 160oC
- Inter finish-polished to SV1

Options:

- 1. Non cavity filler seat

MATERIALS LIST

NO.	PART NAME	MATERIAL
1	BODY	ASTM A351 Gr.CF8M
4	BALL	ASTM A351 Gr.CF8M
5	STEM	SS316
9	END CAP	ASTM A351 Gr.CF8M
11	BODY SEAL	PTFE.
12	SEAT	PTFE.
13	THRUST WASHER	PTFE.
14	STEM PACKING	PTFE.
16	GLAND NUT	SS304
19	HANDLE	SS304
21	HANDLE COVER	PLASTIC
22	STEM NUT	SS304
23	STEM WASHER	SS304
24	HANDLE NUT	SS304
29	BELLEVILLE WASHER	SS304
30	LOCK WASHER	SS304
31	O-RING	VITON
32	RING	SS304
33	STOP PIN	SS304
35	BODY BOLT	SS304
36	BOLT WASHER	SS304
37	BOLT NUT	SS304

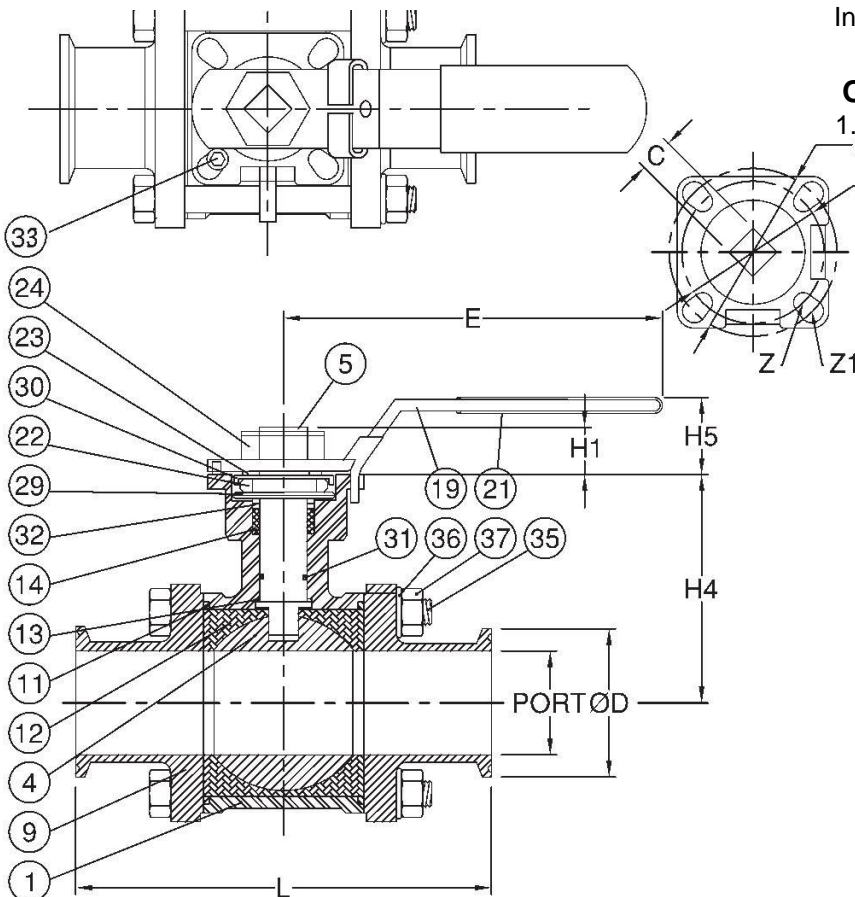

DIMENSIONS

SIZE	PORT	L	E	H1	H4	H5	C	ØD	K	K1	Z	Z1	
DN15	1/2"	9.5	89.0	143.0	9.0	37.0	26.0	9.0	25.4	36.0	42.0	6.0	6.0
DN20	3/4"	15.9	101.0	143.0	9.0	47.0	26.0	9.0	25.4	36.0	42.0	6.0	6.0
DN25	1"	22.2	114.0	160.0	11.0	57.2	34.0	11.0	50.4	42.0	50.0	6.0	8.0
DN40	1-1/2"	35.0	140.0	187.0	14.0	78.2	43.0	14.0	50.4	50.0	70.0	8.0	10.0
DN50	2"	47.6	156.0	187.0	14.0	86.2	43.0	14.0	63.8	50.0	70.0	8.0	10.0
DN65	2-1/2"	60.2	197.0	310.0	17.0	109.2	53.0	17.0	77.6	70.0	102.0	10.0	12.0
DN80	3"	73.0	229.0	310.0	17.0	117.7	53.0	17.0	91.0	70.0	102.0	10.0	12.0
DN100	4"	97.4	241.0	400.0	22.0	141.2	56.0	22.0	119.0	102.0	125.0	12.0	14.0

unit:mm